

## DC Inverter Air Source Heat Pumps (Monoblock Type)

1. Working source temperature range:  $-20^{\circ}\text{C}$  to  $45^{\circ}\text{C}$
2. Control Object: water tank temperature  
(Setting range: Heating:  $30^{\circ}\text{C} \sim 55^{\circ}\text{C}$ ; Cooling:  $32^{\circ}\text{C} \sim 12^{\circ}\text{C}$ )
3. Control Way: wire controller
4. Water Pump: start/stop according to water tank temp
5. Modes: hot water/house heating/house cooling

**SPRSUN**



**Guangzhou Sprsun New Energy Technology Development Co., Ltd.**

Unit Name		DC Inverter Air Source Heat			
Model		CGK020V2			
Power Supply / Refrigerant		V/Hz/Ph	220-240/50/1 - R410A		
Max. Heating Capacity (1)		kW	7.5		
C.O.P (1)		W/W	4.45		
Heating Capacity Min./Max.(1)		kW	3.45 / 7.5		
Heating Power Input Min./Max.(1)		W	620 / 1685		
C.O.P Min./Max.(1)		W/W	4.45 / 5.56		
Max. Heating Capacity(2)		kW	7.1		
C.O.P (2)		W/W	3.60		
Heating Capacity Min./Max.(2)		kW	3.24 / 7.05		
Heating power input Min./Max.(2)		W	767 / 1980		
C.O.P Min./Max.(2)		W/W	3.56 / 4.23		
Max. Cooling Capacity(3)		kW	6.7		
E.E.R (3)		W/W	3.50		
Cooling Capacity Min./Max.(3)		kW	3.08 / 6.70		
Cooling Power Input Min./Max.(3)		W	744 / 2267		
E.E.R Min./Max.(3)		W/W	2.95 / 4.14		
Max. Cooling Capacity(4)		kW	5.3		
E.E.R(4)		W/W	2.62		
Cooling Capacity Min./Max.(4)		kW	2.43 / 5.29		
Cooling Power Input Min./Max.(4)		W	667 / 2105		
E.E.R Min./Max.(4)		W/W	2.51 / 3.65		
Max. Cooling Capacity(7)		kW	5.0		
E.E.R(7)		W/W	1.97		
Cooling Capacity Min./Max.(7)		kW	2.31 / 5.02		
Cooling Power Input Min./Max.(7)		W	720 / 2353		
E.E.R Min./Max.(7)		W/W	2.13 / 3.21		
Max. Heating Capacity (5)		kW	5.7		
C.O.P(5)		W/W	3.44		
Heating Capacity Min./Max.(5)		kW	2.62 / 5.70		
Heating Power Input Min./Max.(5)		W	610 / 1657		
C.O.P Min./Max.(5)		W/W	3.44 / 4.30		
Max. Heating Capacity (6)		kW	5.5		
C.O.P(6)		W/W	2.92		
Heating Capacity Min./Max.(6)		kW	2.55 / 5.53		
Heating Power Input Min./Max.(6)		W	698 / 1896		
C.O.P Min./Max.(6)		W/W	2.92 / 3.65		
Rated Current		A	8.1		
Max Power Input		kW	2.4		
Max Current		A	11.69		
Compressor	Type - Quantity/System	Twin Rotary - 1			
Fan	Quantity	1			
	Airflow	m3/h	3000		
	Rated power	W	100		
Water Side Heat Exchanger	Type	Plate Heat Exchanger			
	Water Pressure Drop	kPa	16		
	Piping Connection	Inch	G1"		
Allowable Water Flow	Min./Rated./Max.	L/S	0.22	0.36	0.60
Noise Level		dB(A)	59		
Net Dimension(L×D×H)		mm	1110*475*810		
Packing Dimension(L×D×H)		mm	1220*540*970		
Net Weight		Kg	88		
Gross Weight		Kg	116		
Note: (1) Heating condition: water inlet/outlet temperature: 30°C/35°C, Ambient temperature: DB 7°C/WB 6°C;					
(2) Heating condition: water inlet/outlet temperature: 40°C/45°C, Ambient temperature: DB 7°C/WB 6°C;					
(3) Cooling condition: water inlet/outlet temperature: 23°C/18°C, Ambient temperature: DB35°C/WB24°C;					
(4) Cooling condition: water inlet/outlet temperature: 12°C/7°C, Ambient temperature: DB35°C/WB24°C;					
(5) Heating condition: water inlet/outlet temperature: 30°C/35°C, Ambient temperature: DB -7°C/WB -8°C;					
(6) Heating condition: water inlet/outlet temperature: 40°C/45°C, Ambient temperature: DB -7°C/WB -8°C;					

# Functions

## 1. How to Start Electric Heater?

There are two kinds of electric heaters: backup electric heater and crank heater. The corresponding electric heater can be enabled in M04 menu.

In heating mode (without defrosting), start backup electric heater when all the following conditions are met:

- (1) Enable the backup electric heater function;
- (2) Ambient temperature  $\leq$  the ambient temperature when starting electric heater (default value  $0^{\circ}\text{C}$ );
- (3) Target temperature  $\leq$  heating temperature set point - deviation value under electric heating (default value  $5^{\circ}\text{C}$ );
- (4) It takes more than 5min to start the compressor (adjustable);

In heating mode (without defrosting), turn off backup electric heater if any of the following conditions are met:

- (1) Ambient temperature  $\geq$  the ambient temperature when starting electric heater +  $3^{\circ}\text{C}$ ;
- (2) Target temperature  $\geq$  heating temperature set point;
- (3) Ambient temperature sensor error;
- (4) Power off.

## 2. How to Enter Defrosting?

When the air-cooled unit is in the heating mode, the outdoor coil works as evaporator. If the outdoor temperature is too low, frost may form on the coil, which means that the working efficiency of the unit is reduced. In this case, the heating mode should be temporarily switched to the cooling mode for defrosting and then return to the heating mode, so that the unit can resume its high efficiency.

Defrosting Conditions:

Defrosting will be enabled when the following conditions are met at the same time:

- (1) Time between two defrosting cycles  $\geq$  defrosting interval, unit: min, default value: 45;
- (2) Ambient temperature  $\leq$  defrosting ambient temperature, lasting for 2s, default value is  $15^{\circ}\text{C}$  (this condition is ignored when there is ambient temperature sensor error);
- (3) Ambient temperature - evaporation temperature  $\geq$  defrosting temperature difference, lasting for 2s, the default value is  $5^{\circ}\text{C}$ ; this condition is ignored when there is ambient temperature sensor error;
- (4) Evaporation temperature  $\leq$  defrosting set point, lasting for 2s, default value  $-1^{\circ}\text{C}$ ;

Defrosting set point: according to the compensation of ambient temperature, the lower the ambient temperature is, the lower the setting point will be.

Implementing the manual forced defrosting command will ignore the above entry conditions.

Defrosting will quit if any of the following conditions is met:

- (1) Defrosting time  $\geq$  maximum defrosting time, the default value is 8min;
- (2) Condensation/coil temperature  $\geq$  the setting point of exiting defrosting, default value  $15^{\circ}\text{C}$ ;
- (3) Power off.

## Heating Capacity at Different Conditions

Model	CGK020V2		
Air temp °C	Heating capacity (KW)		
-20	3.46	2.94	0.88
-15	4.62	3.91	2.35
-7	5.68	5.51	5.02
2	6.68	6.49	6.29
7	7.50	7.05	6.70
12	7.88	7.40	7.03
20	8.27	7.77	7.38
Hot water temp °C	30/35	40/45	50/55

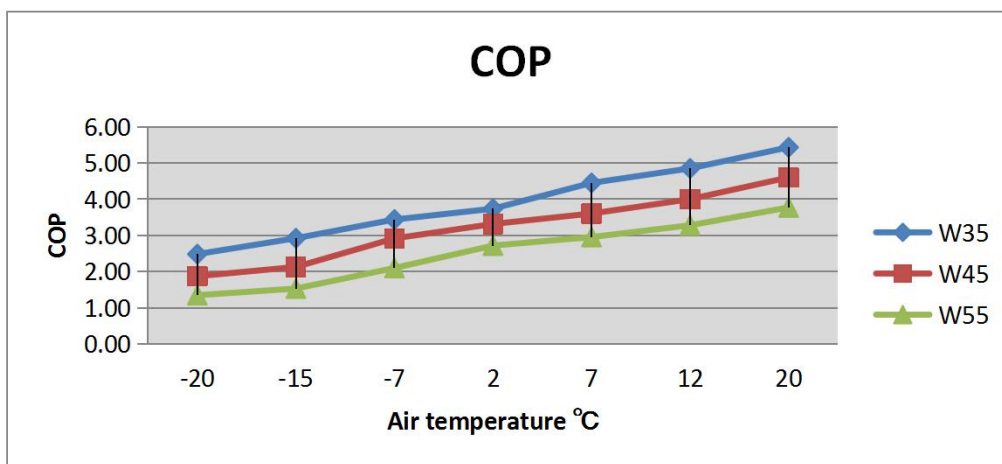

Air temp °C	COP kW/kW		
-20	2.48	1.87	1.35
-15	2.92	2.13	1.53
-7	3.44	2.92	2.10
2	3.74	3.32	2.72
7	4.45	3.60	2.96
12	4.85	4.00	3.28
20	5.43	4.60	3.77
Hot water temp °C	35	45	55

## Installation Diagram

Symbol	Name
	3-way valve
	2-way valve
	Ball valve
	Non-return valve
	Filter
	Water pump
	Temp sensor
	Release valve
	Expansion tank

**Notice:**

1. Pls select the right modes according to your demand then install it according to the installation diagram. If only hot water function required, pls select heating+hot water mode , and then put the hot water sensor into the hot water tank.
2. Two-way valve and BV valve are optional for installation. Only If you need to control the temperature by different zone, then pls install both.
3. Fan coil can be controlled by linkage with the secondary circulation pump . Meanwhile, a passive linkage thermostat shall be installed.

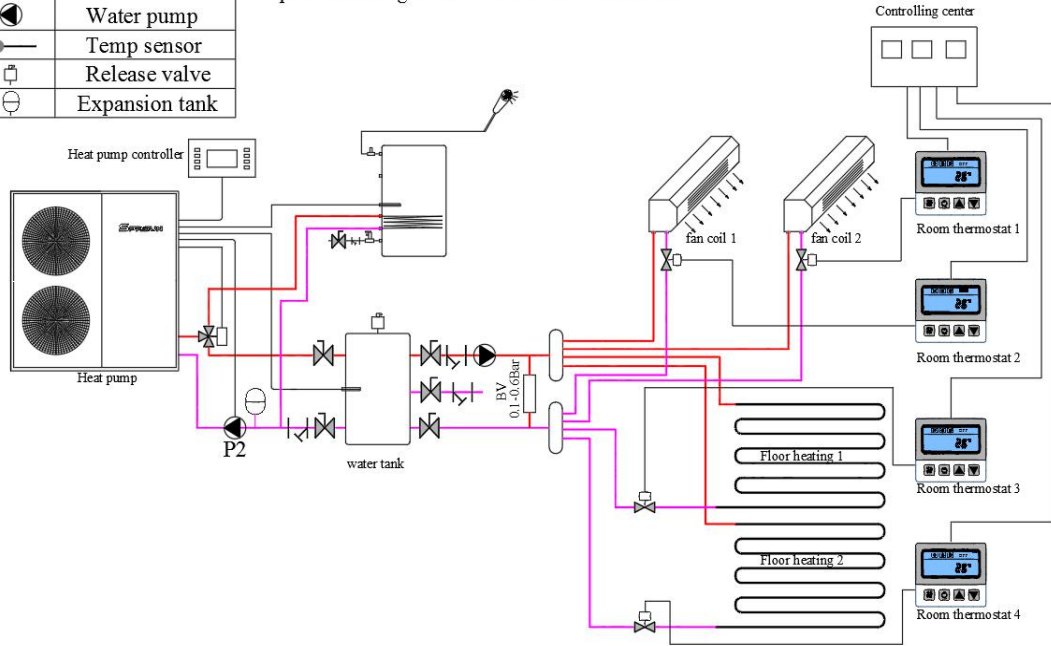

SPRSUN DC inverter air source heat pump

Symbol	Name
	3-way valve
	2-way valve
	Ball valve
	Non-return valve
	Filter
	Water pump
	Temp sensor
	Release valve
	Expansion tank





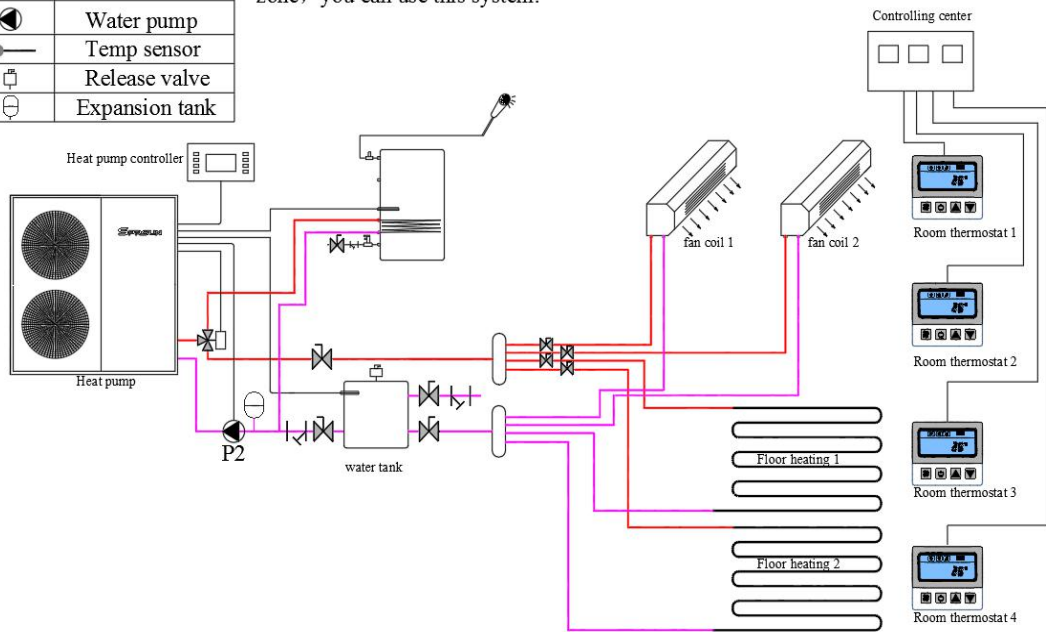

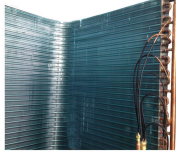

**Notice:**

1. Pls select the right modes according to your demand then install it according to the installation diagram. If only hot water function required, pls select heating+hot water mode , and then put the hot water sensor into the hot water tank.
- Fan coil can be controlled by linkage with the secondary circulation pump . Meanwhile, a passive linkage thermostat shall be installed.
3. This is primary circulation system, If you not need to control the temperature by different zone, you can use this system.



SPRSUN DC inverter air source heat pump

## Standard Materials

Name	Description	Picture	Name	Description	Picture	Name	Description	Picture
Condenser (copper)	Plate Heat Exchanger		Evaporator	Hydropilic Aluminium foil and internal thread copper pipe heat exchanger		High Pressure Sensor	0-4.5MPa	
Compressor	Panasonic Rotary Compressor		Expansion Valve	CAREL Electronic expansion valve		Low Pressure Sensor	0-3.45MPa	
4-way valve	SANHUA		AC Contactor and Thermal Relay	Eaton (Former brand is Moeller)		Package	corrugated board case / plywood case	
Controller	CAREL Controller		DC Fan	WOLONG DC Fan	